



### Dear business partners and clients!

In order to correspond to our clients' demands, alternatively we are pleased to offer renewed second hand machines, equipment and spare parts too.  
Don't hesitate to contact us, even if you are looking for special purpose machines.

### Chemical seed treating

#### **1 complete chemical seed treater plant – NEW for mobile or stationary application**

User-friendly with precisely working seed treater for cereals and legumes

- with bucket elevator (PVC buckets) for easy feeding
- chemical seed treater installed on a revolving chassis for various bagging options
- supporting construction with height-adjustable legs
- for manipulation by forklift or by tractor (3 attachment points)

Capacity: 4-5 t/h (based on wheat)

seed treater for wet and optionally for powdery pickling agent  
continuous mode of operation by tilting with 2 weighing bowls à 5 kg  
gentle product treating - mixer equipped with rubber paddles

Optional execution: second circuit for soya inoculation

Price on request.





## Cleaning and Sorting

### **1 pc. RUBERG aspirator (cleaning by air and screens) type RVS 80 - RENEWED aspiration – cleaning - sorting**

- capacity: 80 t/h precleaning and approx. 9 t/h. seed cleaning (based on wheat)
- total screen surface: 18 m<sup>2</sup>
- working in recirculating-air mode (only 10 % exhaust air → less dedusting performance required)
- horizontally rotating sieve movement guarantees highest cleaning efficiency

Sample photos of an overhauled RUBERG aspirator (incl. new painting)



Furthermore there may soon be RUBERG aspirators with performances up to 150 t/h available for general overhaul.

We look forward to your inquiry.



**1 pc. Cimbria Super Fine Cleaner type DELTA 104 – AS NEW**

Year of construction: 2021

Capacity: up to 5 t/h based on wheat and 750 kg-1.000 kg/h based on grass seeds

For highest quality cleaning of seeds, malting barley, grass and garden seeds.

Price on request.

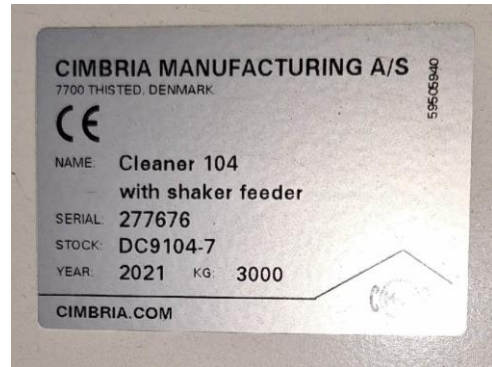

**1 pc. cyclone brand JKF type CS-11 – NEW not used**

Ø 1.550 mm, left execution

galvanized

Special price € 2.495,00

Accessories:

1 pc. frame for installation on the floor

free height 1,6 m

painted RAL 5010 (gentian blue)

Special price € 950,00

as well as:

1 pc. slider for installation under the cyclone

manually operated

Ø 300 mm

Special price € 295,00

All accessories are new, not used!

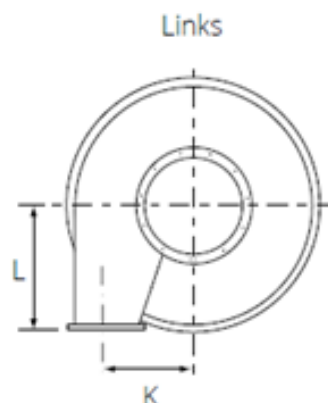



**Storing and Drying**



**Storage containers also with outlet on the smaller side – NEW side especially for loading a seed drill**  
painted / galvanized or in stainless steel execution  
stackable, with forklift tracks from 4 sides  
Multiple applications and easy handling:



Here with wheels and outlet spout.



**Special containers for collecting ash or dust.**  
**Stainless steel containers for wet pumpkin seeds**



### New GALVANIZED container types applicable also for the storage of wood pellets

#### A) type VZ-TM with hopper and outlet slider

dimensions: 1230 x 1070 x 1640 mm (l x w x h)  
bolted construction - galvanized  
capacity 1,3 m<sup>3</sup>  
dimensions of outlet slider: 200 x 200 mm (l x w)  
with forklift tracks on 2 sides  
stackable.

#### B) type VZ-LC with flat bottom without outlet

dimensions: 1300 x 1140 x 1340 mm (l x w x h)  
bolted construction - galvanized  
capacity 1,4 m<sup>3</sup>  
to be emptied by tilting  
with forklift tracks on 2 sides  
stackable.





**Dust-collecting containers with lateral discharge door or bottom outlet  
Execution accord. to customer's specification!**





**Big-Bag bagging rack – AS NEW**

1,37 x 1,37 x 2,75 m (l x w x h)

Height adjustable for Big-Bags of height up to 1,6 m

Painted white.

Price on request.

sample picture:

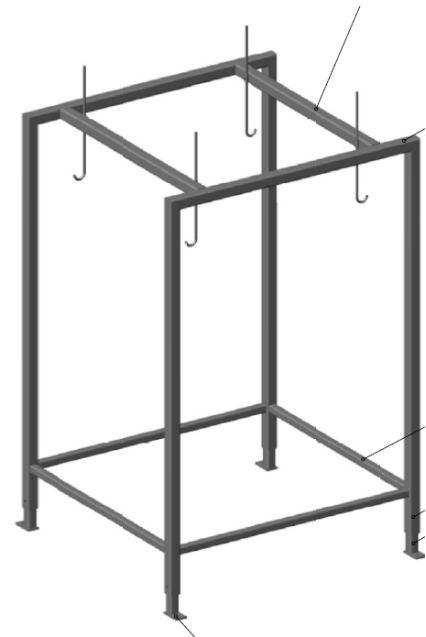

**Constructions for the container – BigBag bagging**

Execution accord. to customer's specification!

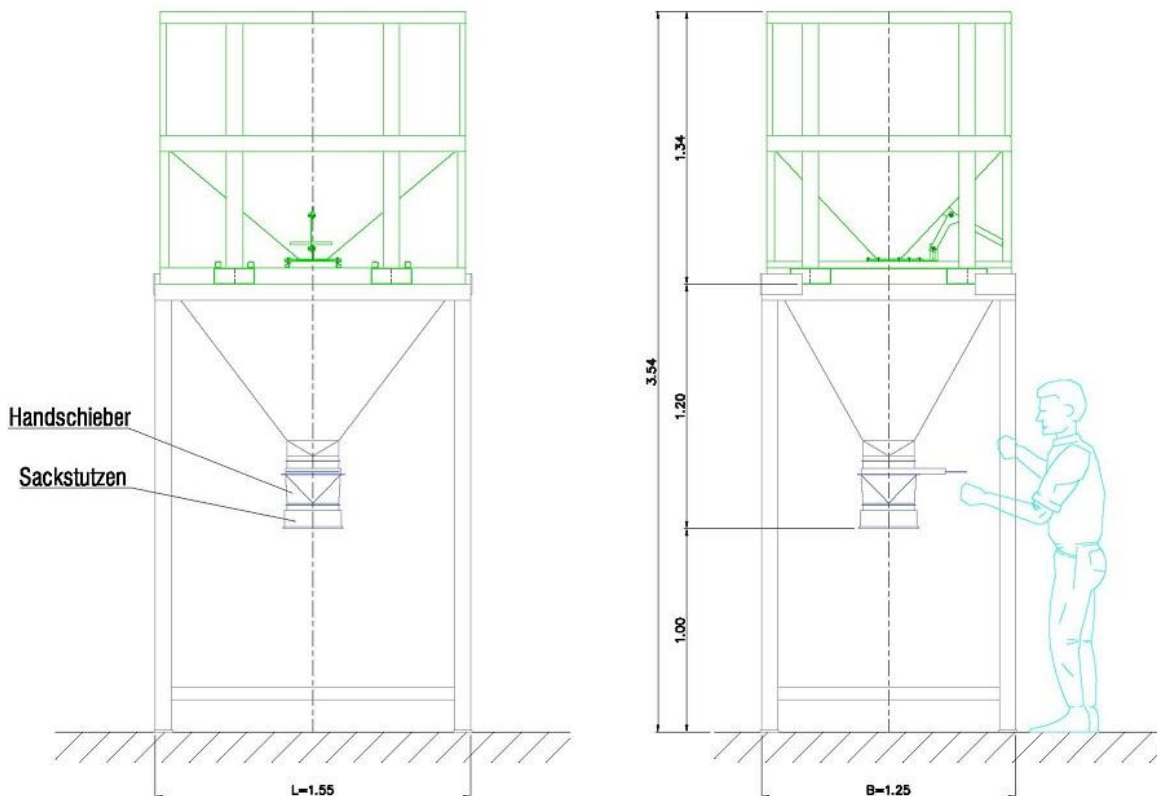



**Further equipment**



**1 pc. gross Bagging Scale for 30 – 50 kg**

Mechanical operation.

Price on request.

**1 pc. fuel oil burner type OKLIMA SE 200 - NEW**

heat output: 55 kW

for indirect heating

**Netprice EXW Niederfellabrunn € 2.715,--**

*Kindly inform us if you have any demand on further seed cleaning- or milling equipment.*

**ALL SECOND HAND MACHINES ARE SUBJECT TO PRIOR SALE!**

**Prices:** net, ex work, if available

Best regards,  
HDT GmbH